

REV	DESCRIPTION	APPR	CHECK	DRAW	DATA
△	?????			JANET	040719

Ordering Information

HI 1 C 19 - C X 01 X

COLOR/MATERIAL:  
C=BLACK/LCP

- Contact Area Plating
- 5:15? " Gold/TIN
  - 6:30? " Gold/TIN
  - 7:Gold Flash/TIN
  - 5A:15? " Gold/MATTE TIN
  - 6A:30? " Gold/MATTE TIN
  - 7A:Gold Flash/MATTE TIN
  - 5B:15? " Gold/TIN(SHELL WITH GOLD)
  - 6B:30? " Gold/TIN(SHELL WITH GOLD)
  - 7B:Gold Flash/TIN(SHELL WITH GOLD)
  - ...

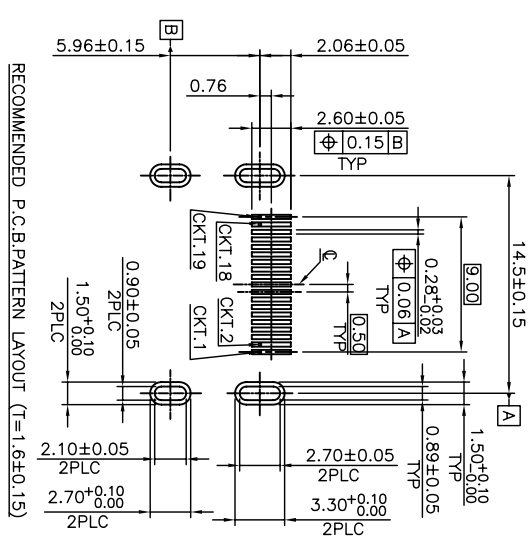
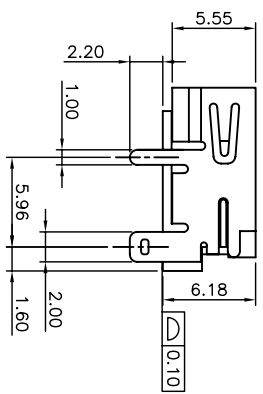
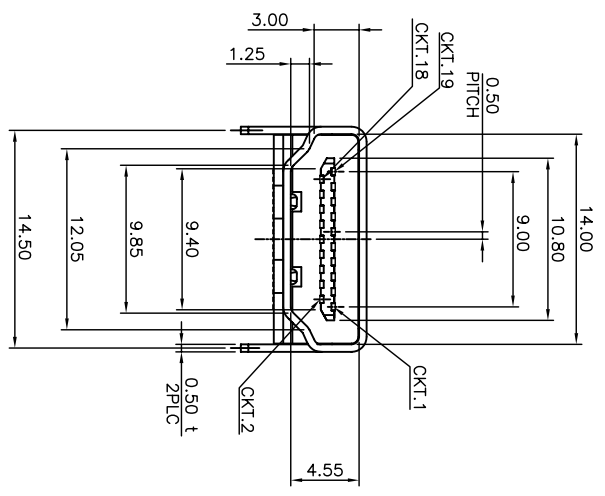
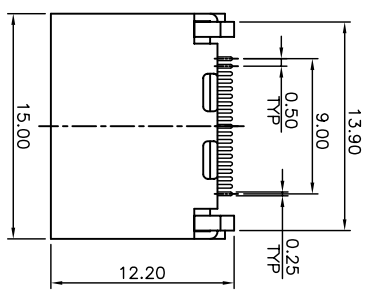

RECOMMENDED P.C.B.PATTERN LAYOUT (T=1.6±0.15)

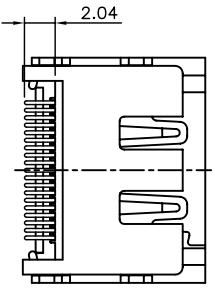

NOTES:  
1.MATERIAL:  
HOUSING:THERMOPLASTIC WITH 30% G/F, UL 94V-0  
COLOR:BLACK  
CONTACT:PHOSPHOR BRONZE  
SHELL:PHOSPHOR BRONZE  
2.FINISH:  
CONTACT:15U" GOLD/TIN PLATING ON CONTACT AREA  
100U" MIN.TIN PLATING ON SOLDERAILS  
50U" MIN.NICKEL UNDERPLATING OVER ALL  
SHELL:  
50U" MIN.NICKEL UNDERPLATING OVER ALL  
&  
GOLD FLASH GOLD UNDERPLATING OVER ALL

QUALITY SYMBOLS	GENERAL TOLERANCES (UNLESS SPECIFIED)	SCALE:	NUMBER:
▽0	MM	2.5:1	
▽0	INCH		

TITLE:	DRAWN BY:	DATE:	CHECKED BY:	DATE:	APPROVED BY:	DATE:
E-GREEN ENTERPRISE CO., LTD.	JANET	050525	JANET	050525	ROCKY	050525

THIRD ANGLE PROJECTION	REVERSE ON CAD ONLY	PART NO.:	DWG NO.:	SHEET NO.:
THIRD ANGLE PROJECTION	REVERSE ON CAD ONLY	HIC19-CX01X	HI-1001	1/1

DRAFT WHERE APPLICABLE MUST REMAIN WITHIN DIMENSIONS

